



SEMS Portal App



LinkedIn



Company's Official Website

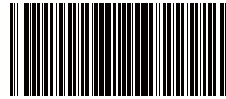

340-00535-00

#### GOODWE (China)

No. 90 Zijin Rd., New District, Suzhou, 215011, China  
T: +86 (0) 512 6958 2201  
sales@goodwe.com (sales)  
service@goodwe.com (service)

#### GOODWE (Germany)

Fürstenrieder Str. 279a 81377 München, Germany  
T: +49 8974120210 +49 421 83570-170 (service)  
sales.de@goodwe.com  
service.de@goodwe.com

#### GOODWE (Netherlands)

Franciscusdreef 42C, 3565AC Utrecht, the Netherlands  
T: +31 (0) 30 737 1140  
sales@goodwe.com  
service.nl@goodwe.com

#### GOODWE (India)

1202, G-Square Business Park, Sector 30A, Opp. Sanpada Railway Stn., Vashi, Navi Mumbai- 400703  
T: +91 (0) 2249746788  
sales@goodwe.com / service.in@goodwe.com

#### GOODWE (Turbutton)

Adalet Mah. Megapol Tower K: 9 No: 110 Bayraklı - Izmir  
T: +90 (232) 935 68 18  
info@goodwe.com.tr  
service@goodwe.com.tr

#### GOODWE (Mexico)

Oswaldo Sanchez Norte 3615, Col. Hidalgo, Monterrey, Nuevo Leon, Mexico, C.P. 64290  
T: +52 1 81 2871 2871  
sales@goodwe.com / soporte.latam@goodwe.com

#### GOODWE (Brazil)

Rua Abelardo 45, Recife/PE, 52050-310  
T: +55 81 991239286  
sergio@goodwe.com  
servico.br@goodwe.com

#### GOODWE (UK)

6 Dunhams Court, Dunhams Lane, Letchworth Garden City, SG6 1WB UK  
T: +44 (0) 333 358 3184  
enquiries@goodwe.com.uk / service@goodwe.com.uk

#### GOODWE (Italy)

Via Cesare Braico 61, 72100 Brindisi, Italy  
T: +39 338 879 38 81; +39 831 162 35 52  
valter.pische@goodwe.com (sales)  
operazioni@topsenergy.com; goodwe@arsimp.it (service)

#### GOODWE (Australia)

Level 14, 380 St. Kilda Road, Melbourne, Victoria, 3004, Australia  
T: +61 (0) 3 9918 3905  
sales@goodwe.com / service.au@goodwe.com

#### GOODWE (Korea)

8F Invest Korea Plaza, 7 Heoleung-ro Seocho-gu Seoul Korea (06792)  
T: 82 (2) 3497 1066  
sales@goodwe.com / Larry.Kim@goodwe.com



## XS SERIES USER MANUAL













SOLAR INVERTER

Note: The information above is subject to change without prior notice, for details refer to [www.goodwe.com](http://www.goodwe.com)

Version 2.1  
Date 2021/05/31

<b>1 Symbols</b> .....	<b>01</b>
<b>2 Safety Measures &amp; Warning</b> .....	<b>02</b>
<b>3 Product Introduction</b> .....	<b>04</b>
3.1 Inverter Overview .....	04
3.2 Package .....	05
<b>4 Installation</b> .....	<b>06</b>
4.1 Mounting Instructions .....	06
4.2 Equipment Installation .....	06
4.3 Electrical Connection .....	08
4.4 Communication Connection .....	12
<b>5 System Operation</b> .....	<b>17</b>
5.1 LCD Panel .....	17
5.2 User Interface And System Configuration .....	17
5.3 Error Message .....	23
5.4 Wi-Fi Reset & Wi-Fi Reload .....	23
5.5 Precaution For Initial Startup .....	24
5.6 Special Adjustable Setpoints .....	24
<b>6 Troubleshooting</b> .....	<b>27</b>
<b>7 Technical Parameters</b> .....	<b>29</b>

## 1 Symbols

	Failure to observe a warning indicated in this manual may result in injury.
	Recyclable materials
	Danger of high voltage & electric shock
	This side up - The package must always have the arrows point up
	Don't touch, hot surface!
	No more than eight (8) identical packages be stacked on each other.
	Special disposal instructions
	Fragile
	Keep Dry
	Refer to operation instructions
	Wait at least 5 minutes after disconnecting the inverter before touching internal parts
	CE mark.

## 2 Safety Measures & Warning

The XS-Series strictly conforms and has been tested according to international safety regulations. GOODWE strongly advises installers to follow the local safety regulations during the commissioning, operation and maintenance of the XS-Series inverter. An improper operation may result in electric shocks or damage to equipment and property.

- The installation, maintenance and connection of the inverters must be performed by qualified personnel, in compliance with local electrical standards, regulations and following the regulations of the local power suppliers, companies and related authorities.
- To avoid electric shocks, the DC input and AC output port of the inverters must be disconnected and wait at least 5 minutes before performing any installation or maintenance.
- The temperature of some components of the inverters may exceed 60°C during operation. To avoid being burnt, do not touch the inverter during operation. Let it cool before touching it.
- Keep children away from the inverter.
- Touching or changing inverter components without following the GOODWE's manual instructions may cause personal injury, damage the inverters and ultimately be a reason for warranty invalidation.
- The electronic components of the inverter may be damaged by static electricity. Appropriate methods must be adopted to prevent such damage, otherwise the GOODWE's warranty may be void.
- Make sure that the output voltage of the proposed PV array is lower than the maximum rated input voltage of the inverter; otherwise the inverter may be damaged and the warranty may be void.
- When exposed to sunlight, the PV array generate dangerous high DC voltage; we strongly operators to strictly follow the GOODWE's instructions and avoid actions that put lives at risk.

The PV modules should have as a minimum an IEC61730 class A rating protection.

- If the equipment is used in a way not authorized by the GOODWE, the equipment built-in protections may be damaged.
- In order to achieve a complete isolation of the equipment: Turn off the DC switch, disconnect the DC terminal, the AC terminal and the AC breaker
- Do not insert or pull the AC or DC terminals when the inverter is in operation.
- An earthing photovoltaic system requires the installation of an Arc Fault Detector on the DC side.

The below bullet points are not understandable. Urgently review!

- The inverter can exclude the possibility of DC residual currents to 6mA in the system, Where an external RCD is required in addition to the built-in RCMU, type A RCD must be used to avoid tripping.

- The PV is not grounded as default configuration.



To ensure that the IP65 protection is maintained, please make sure that the inverter is rigorously packed and its component sealed properly. The GOODWE strongly suggests to install the inverter at most one day after it has been unpacked. If this is not the case and the installation takes longer, please re-seal all the unused terminals and ensure that the inverter and its components are not exposed to water or dust.

To our inverter product, GOODWE provides standard manufacture warranty which comes with the product and prepaid warranty extension solution to our customer. You can find the details about the terms and solution from below linkage.

<https://en.goodwe.com/warranty.asp>

## 3 Product Introduction

### 3.1 Inverter Overview

XS series inverter illustration.

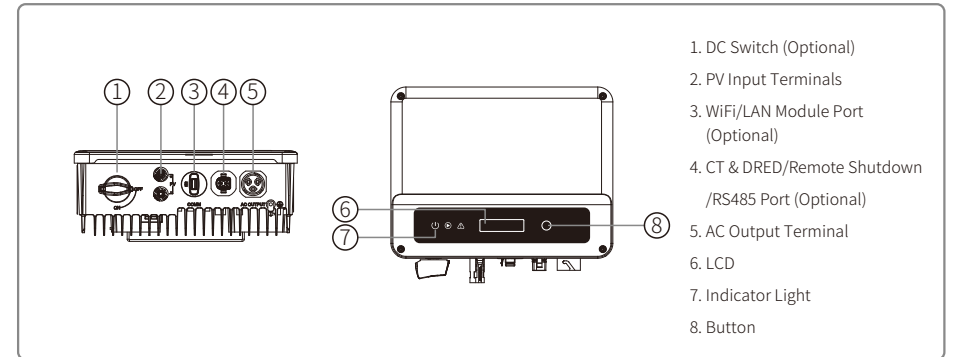

Item	Name	Description
1	DC Switch (Optional)	During normal operation it is in "on" state, it can shut down the inverter after it is disconnected from the grid by the AC breaker.
2	PV Input Terminal	For PV string connection
3	WiFi/LAN Module Port (Optional)	For WiFi/LAN communication
4	CT & DRED/Remote Shutdown/RS485 Communication Port	For CT and DRED & Remote Shutdown & RS485 Communication
5	AC Output Terminal	For AC cable connection
6	LCD	Inverter operation data viewing and parameter configuration.
7	Indicator Light	Display the state of the inverter
8	Button	For configuration and viewing parameters.

## 3.2 Package

The unit is thoroughly tested and strictly inspected before delivery. Damage may still occur during shipping.

1. Check the package for any visible damage upon receiving.
2. Check the inner contents for damage after unpacking.
3. Check the package list below.

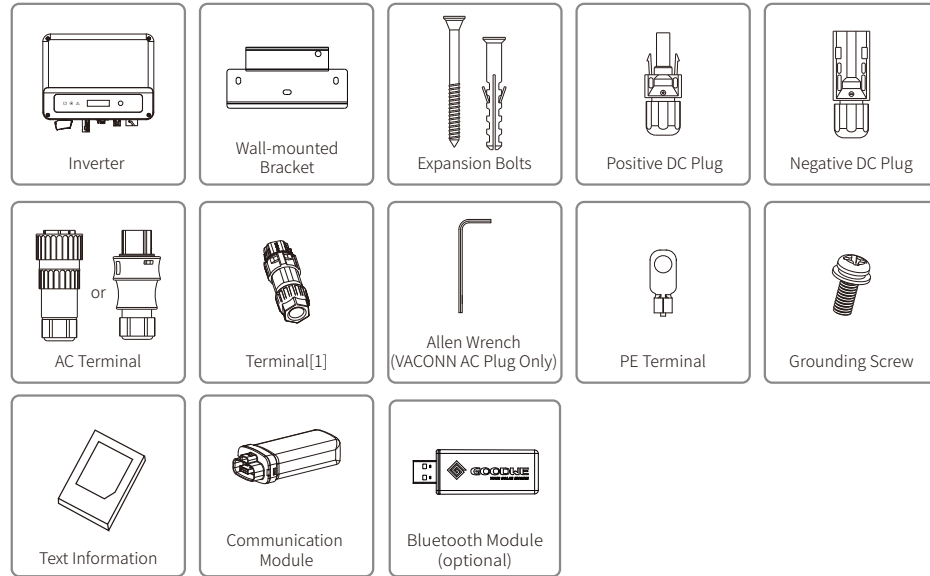

[1] The terminal is used for CT&DRED / Remote Shutdown/ RS485 function.

## 4 Installation

### 4.1 Mounting Instructions

1. In order to achieve optimal performance, the ambient temperature should be lower than 45°C.
2. For easy maintenance, we suggest to install the inverter at eye level.
3. Inverters should not be installed near flammable and explosive items. Strong electro-magnetic charges should be kept away from installation site.
4. Product label and warning symbols should be placed at a location that is easy to read by the users.
5. Make sure to install the inverter at a place where it is protected from direct sunlight, rain and snow.

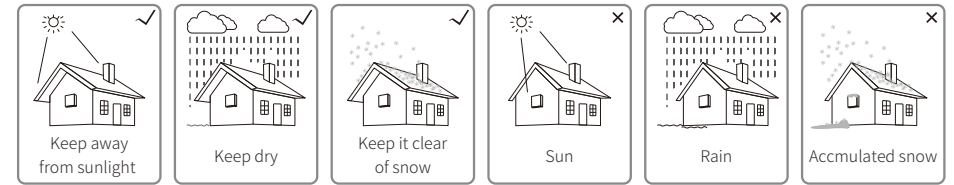

### 4.2 Equipment Installation

#### 4.2.1 Select installation location

Please take the following points into consideration when you are selecting a proper location to install inverter.

- Please choose appropriate mounting methods and installation location in terms of weight and dimension of inverter.
- The location must be well ventilated and sheltered from direct sunlight.
- Install inverter vertically or with a backward tilt within 15 degrees. No lateral tilt is allowed. The inverter should not be tilted sideways. The area of the connectors should point downwards.

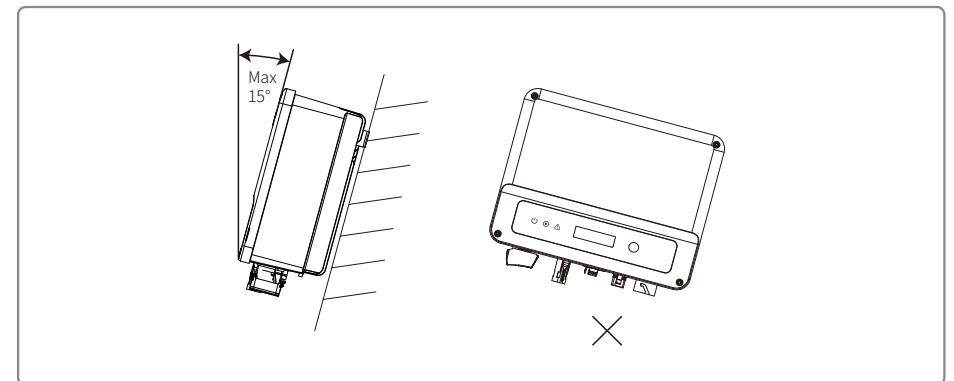

To allow for a dissipation of the heat and in order to facilitate dismantling, the space around the inverter should allow for some clear spaces.

The spacing around inverter should meet the requirements as illustrated in below figures for the sake of heat dissipation and demounting.

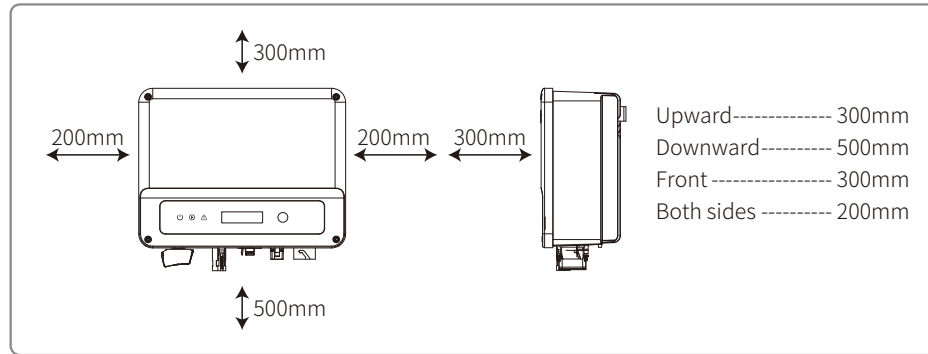

#### 4.2.2 Mounting procedure

1. Use the wall-mount bracket as a template and drill holes with 10mm in diameter and 80 mm in depth on the wall.
2. Fix the wall-mount bracket on the wall with the expansion bolts in the accessories bag.
3. Hold the inverter by the side groove.
4. Mount the inverter onto the wall-mount bracket.

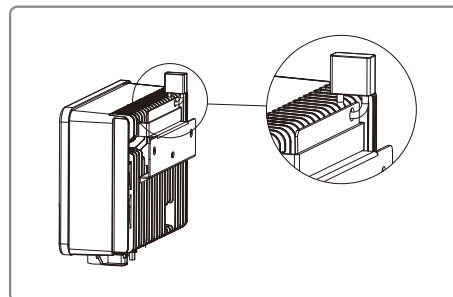
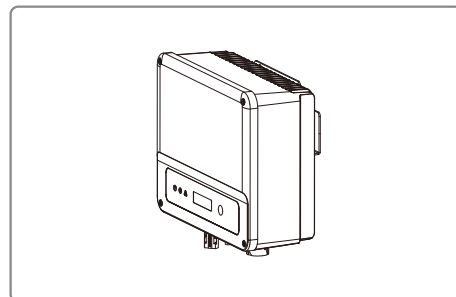
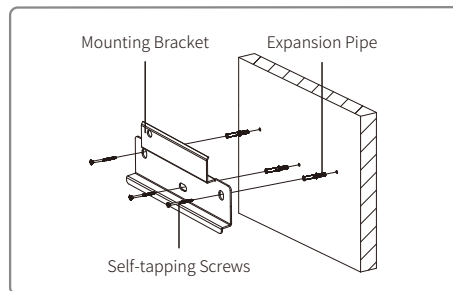
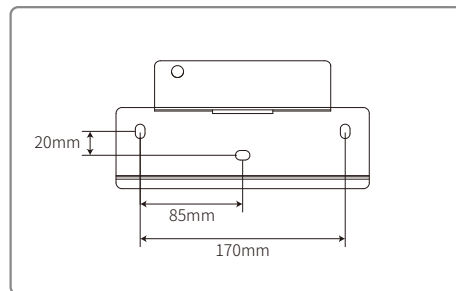

### 4.3 Electrical Connection

#### 4.3.1 Connection To The Grid (AC Side Connection)

1. When connecting the inverter make sure to adjust the voltage and the frequency in compliance with the grid regulations and the specifications of the GOODWE.
2. Add a breaker or fuse to the AC side. Please note that the specification should be more than 1.25 times of rated AC output current.
3. The PE line of the inverter should be connected to earth. Make sure the impedance of neutral wire and earth wire is less than 10ohm.
4. Disconnect the breaker or fuse between the inverter and the utility.
5. Please note that there are two AC connector brands compatible with the inverters: VACONN and Exceedconn. Choose one of the to connect the inverter to the grid.
6. When laying the AC line make sure that the protective earthing conductor is not strained.

Inverter are compatible with two brands of AC connector: VACONN and Exceedconn



#### VACONN AC connectors installation instruction

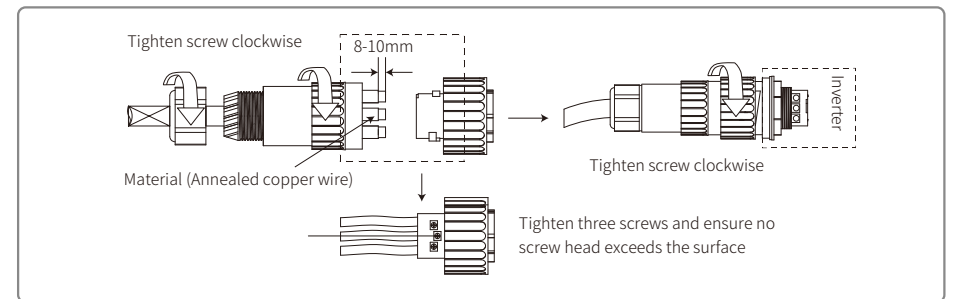

#### Exceedconn connectors installation instruction

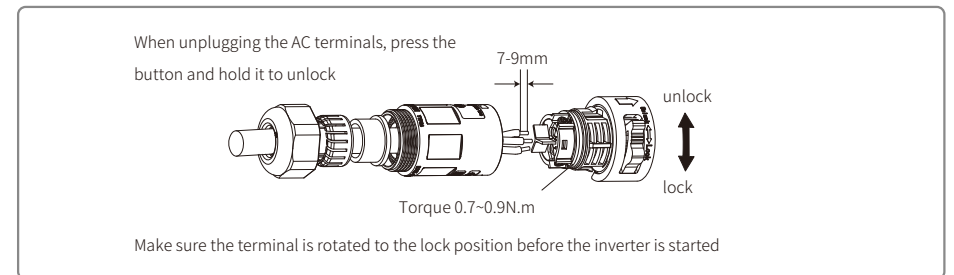

## AC cable specification

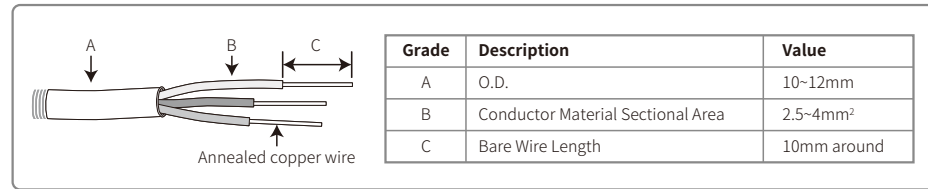

\* Neutral wire is blue, live wire is brown (preferred) or black and protective earth wire is yellow-green.

\* Rotate (tightening torque: 0.6N.m) the connector of AC cable into the corresponding terminal.

### 4.3.2 AC circuit breaker and leakage current protection device

Please install an independent two pole circuit breaker to protect the inverter and make sure it is safe to disconnect it from the grid.

In addition to the built-in RCMU, an external RCD is required to ensure that the inverter system does not carry DC residual currents. To avoid tripping, the types A can be used.

Inverter Model	Recommended Circuit Breaker Specifications
GW700-XS/GW1000-XS/GW1500-XS	16A
GW2000-XS/GW2500-XS/GW3000-XS GW2500N-XS/GW3000N-XS/GW3KB-XS	25A

Note: it is not recommended that multiple inverters share a single circuit breaker.

The integrated leakage current detection device of the inverter can detect external leakage current in real time. When the detected leakage current exceeds the limit value, inverter will quickly disconnect with the grid, if the leakage current protection device is installed externally, the tripping current should be 300mA or higher.

### 4.3.3 DC Side Connection

1. Before connecting the PV strings, please ensure the plug connectors have the correct polarity. Incorrect polarity has the potential to cause permanent damage to the unit.
2. The open circuit voltage of the PV strings cannot exceed the maximum input voltage of the inverter.
3. Only the GOODWE supplied DC connectors are suitable for use.
4. The positive and negative pole should not be connected to the PE wire (ground wire). Not following this instruction may cause damage to the inverter.
5. Do not connect the positive or negative poles of the PV string to the PE wire. Not following this instruction may cause damage to the inverter.
6. Red represents positive, black represents negative.

7. For the XS series the minimum insulation resistance to the ground of the PV panels must exceed 16.7kΩ (R=500/30mA). There is risk of shock hazard if this minimum resistance requirement is not met.

There are four types of DC connectors, DEVALAN, MC4, AMPHENOL H4 and QC4.10 series.

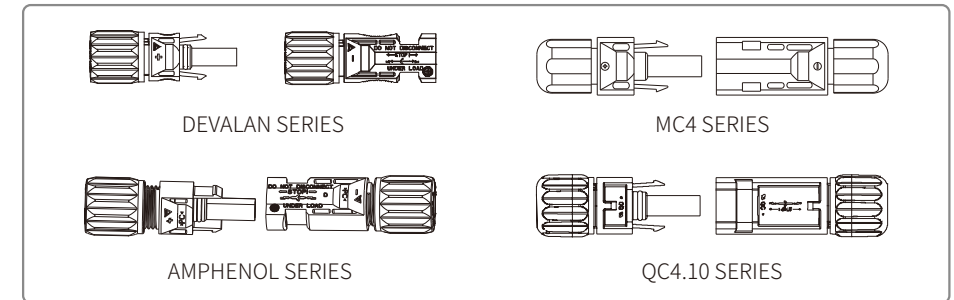

Note: The actual DC connector used is as shown in the accessory box.

DC cable specification:

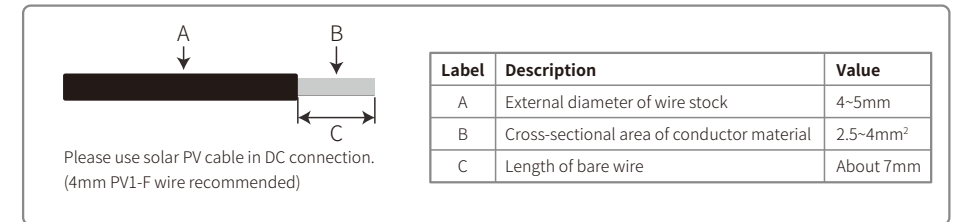

The installation method of DC connector.

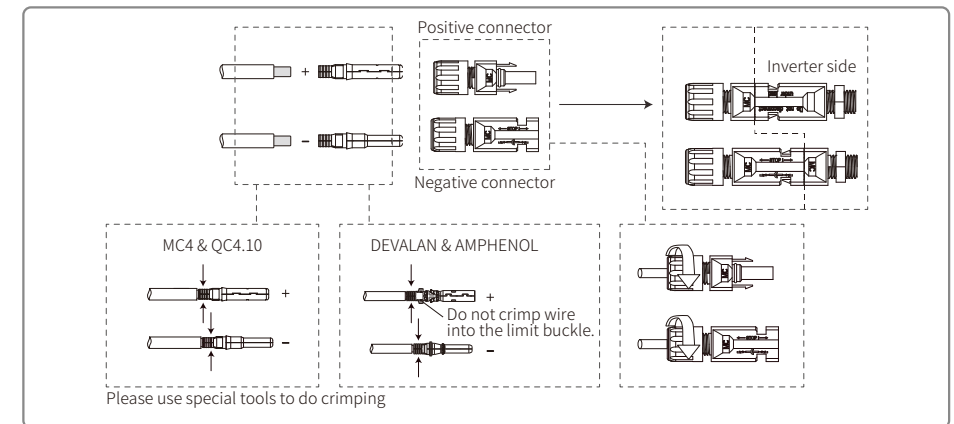

### 4.3.4 Earth Terminal Connection

The inverter is equipped with earth terminal according to the requirement of EN 50178.

All non-current carrying exposed metal parts of the equipment and other enclosures in the PV power system must be grounded.

Please follow the steps below to connect "PE" cable to ground.

#### Step 1

Strip the wire insulation sheet of a suitable length with a wire stripper.

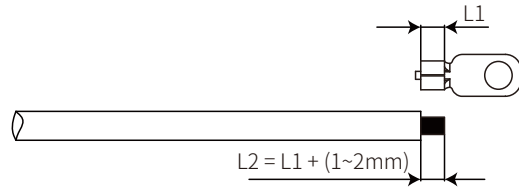

#### Step 2

Insert the stripped wire into the terminal and compress it tightly by crimping pliers.

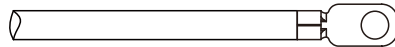

#### Step 3

Fix the earth wire on the machine.

In order to improve the corrosion resistance of the terminal, it is recommended to apply silica gel on the earth terminal for corrosion protection after the grounding cable assembly is completed.

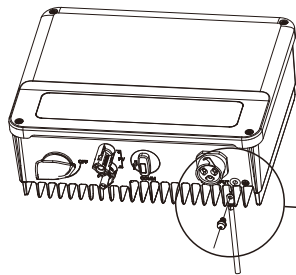

NO.	Name	Explanation
A	Cold-pressed terminal	
B	Screw	M5*14 (1-1.5Nm)
C	Green & Yellow Cable	4mm <sup>2</sup> / 10AWG

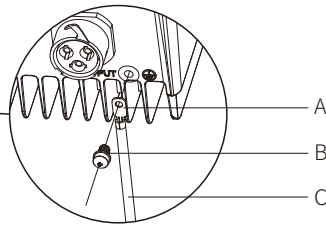

### 4.4 Communication Connection



This port is used for connection of Wi-Fi or LAN module only. No connection to USB is allowed. Do not connect PC or other devices to this port.

#### 4.4.1 Wi-Fi Communication

Wi-Fi communication option is only applicable to Wi-Fi version inverter and Wi-Fi communication module is required. Please refer to "Wi-Fi Configuration Instruction" in the accessory box for detailed instruction.

The WiFi module installation of XS series are shown as below.

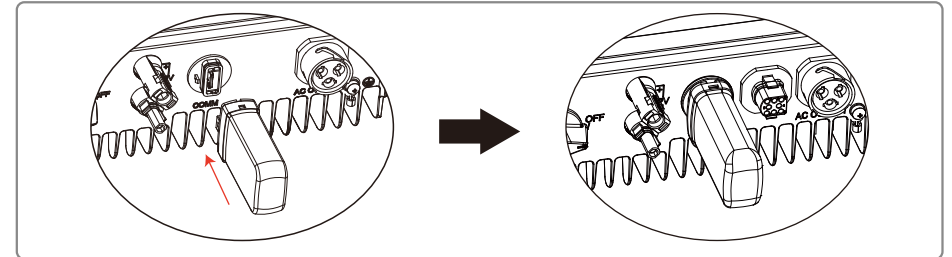

After the installation, confirm whether the indicator on the module is on. If the indicator is off, the module needs to be unplugged and installed again.

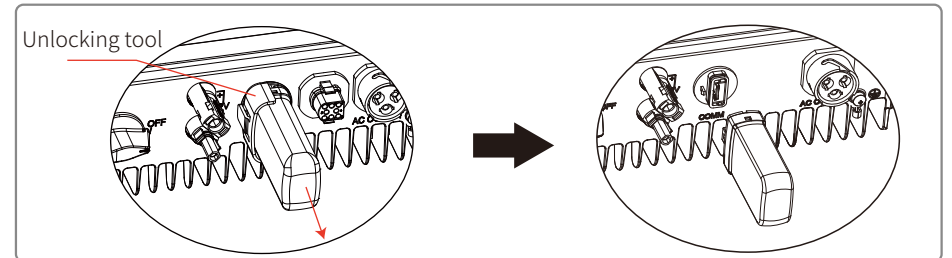

#### 4.4.2 LAN Communication

LAN Communication is only application to LAN version inverter and LAN Communication module is required.

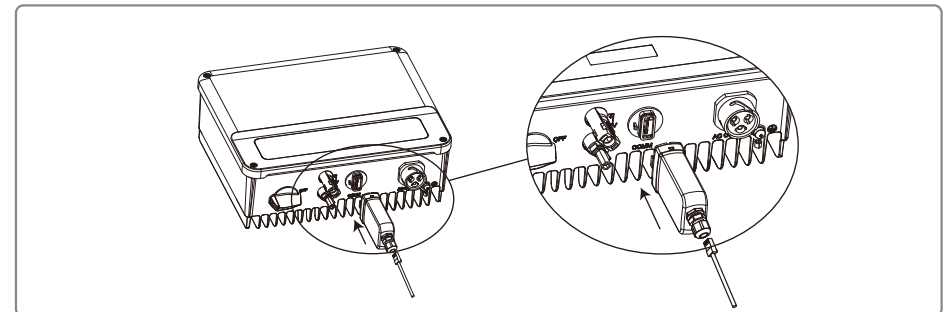



#### 4.4.2 RS485 Communication

RS 485 communication option is only applicable to RS485 version inverter and RS485 communication function is required.

RS485 communication connection of XS series are shown as below.

##### Step 1

Dismount the terminal in the accessory box.

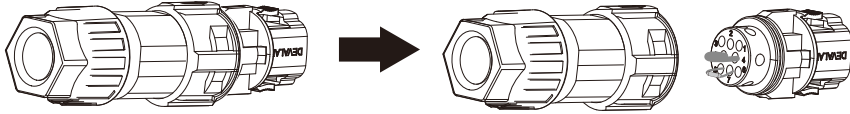

##### Step 2:

Dismantle the resistor or shortcircuit cable.

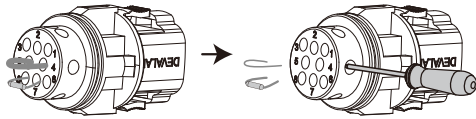

##### Step 3:

Put the cable through the connector and connect to the terminal.

##### For single inverter connection

Please connect RS485 cables to 'RS485-' port (3 or 7) and 'RS485+' port (6 or 8).

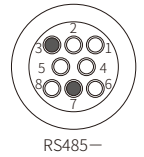
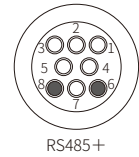
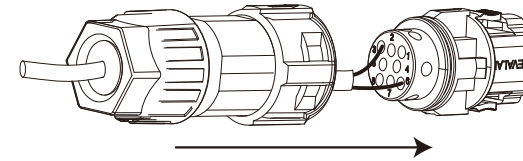

NO.	Function
3	RS485-
7	
6	RS485+
8	

##### For multiple inverter connection

Please connect RS485 cables to 'RS485-' port (3 or 7) and 'RS485+' port (6 or 8).

Note: When in multi-machine parallel, please ensure that terminals at both ends of the 2-pin cable are connected with the same polarity.

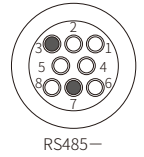
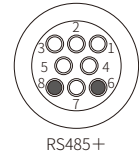
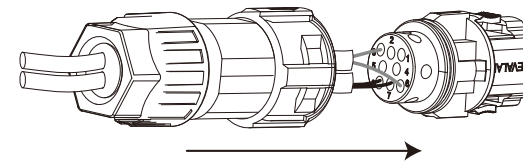

NO.	Function
3	RS485-
7	
6	RS485+
8	

##### Step 4:

Connect the terminal to the right position onto the inverter.

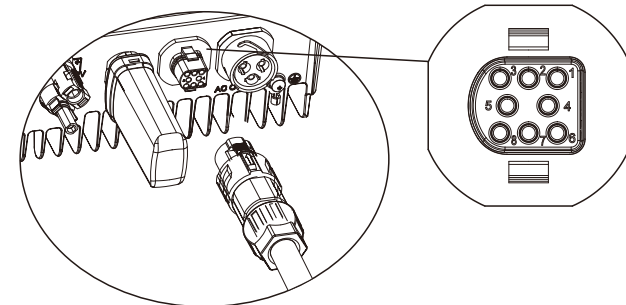

#### 4.4.3 Export Power Limit Connection Diagram

The methods of connecting the Power Limiting device CT is shown below.

CT90-5 or CT90-30 is recommended.

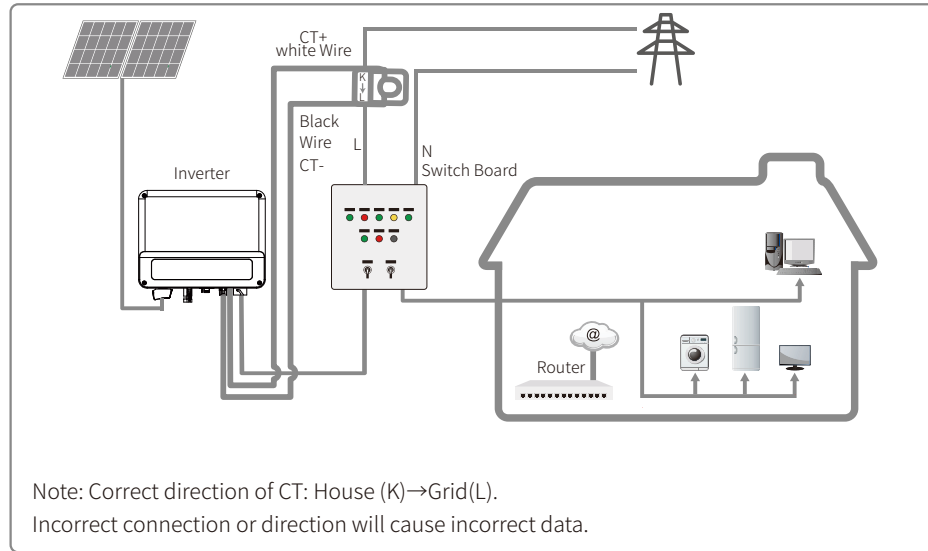

#### 4.4.4 DRED / Remote Shutdown / CT(Power Limit Device) Connection

DRED (Demand response enabling device) is only for Australian and New Zealand installations, in compliance with Australian and New Zealand safety requirements. And DRED is not provided by manufacturer.

Remote shutdown is only for Europe installations, in compliance with European safety requirements. And Remote shutdown device is not provided by GOODWE.

Detailed operation is shown as below:

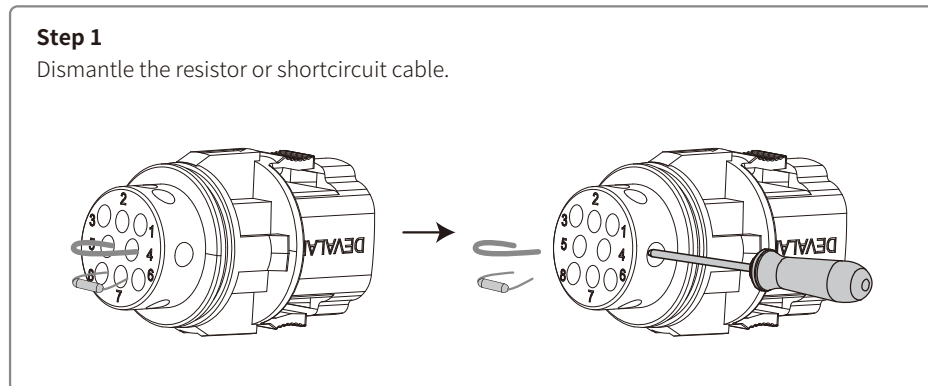

**Step 2:**

Put the cable through the plate.

Different cable and connection method should be applied for different functions. Please follow the connection steps in accordance to the function in need.

**CT and DRED**

Please connect the cables in order as shown in the right table.

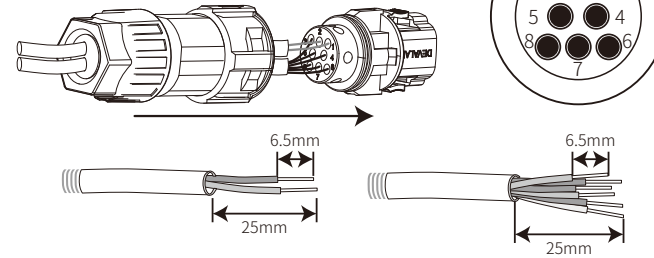

NO.	Function
1	CT +
2	CT -

NO.	Function
3	DRM1/5
4	DRM2/6
5	DRM3/7
6	DRM4/8
7	REFGEN
8	COM/DRM0

**Remote Shutdown**

Please connect the cables in order as shown in the right table.

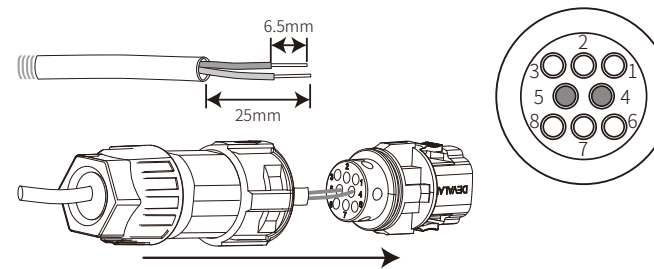

NO.	Function
4	Content +
5	Content -

**CT and Remote Shutdown**

Please connect the cables in order as shown in the right table.

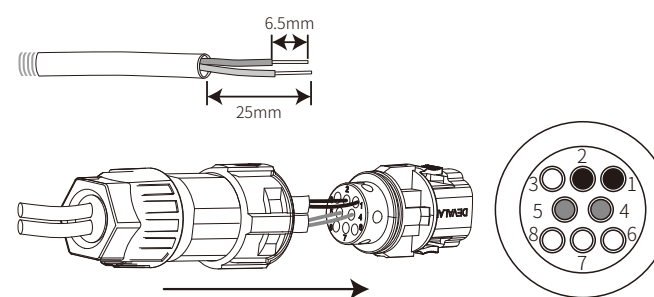

NO.	Function
1	CT +
2	CT -

NO.	Function
4	Content +
5	Content -

### Step 3:

Connect the terminal to the right position onto the inverter.

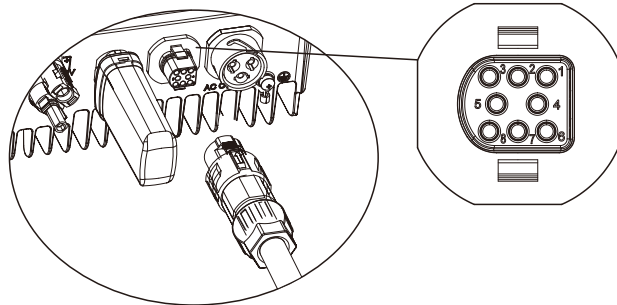

Note:

1. Compatible DRED commands are DRM0, DRM5, DRM6, DRM7, DRM8.
2. Please set up power limit function at local setting page once all connection steps are done.
3. CT is directional. Please make sure CT+ is properly connected to white & black wire and CT- to black wire. Please make sure the limit buckle is connected to the output live wire (L) of inverter.
4. If CT is not well connected, it will display "CT disconnected" on the inverter. If CT is reversely connected, it will display "CT Reverse" on the inverter when connected to grid.

#### 4.4.5 Earth Fault Alarm

In compliance with the section 13.9 of IEC62109-2, the XS series inverter is equipped with an earth fault alarm. When earth fault occurs, the fault indicator at the front LED screen will light up. On inverters with Wi-Fi communication, the system sends an email with the fault notification to the customer. For inverters without Wi-Fi, the buzzer of the inverter will keep ringing for one minute and ring again after half an hour until the fault is resolved. (This function is only available in Australia and New Zealand).

#### 4.4.6 SEMS Portal

SEMS Portal is an online monitoring system. After completing the installation of communication connection, you can access [www.semsportal.com](http://www.semsportal.com) or download the App by scanning the QR code to monitor your PV plant and device.

Please contact the after-sales for more operation of SEMS Portal.















SEMS Portal App

## 5 System Operation

### 5.1 LCD Panel



Indicator lights in Yellow/Green/Red correspondently refer to: ☰ / ▶ / ⚠

Indicator	Status	Explanation
 Power		ON = WiFi connected/active
		BLINK 1 = WiFi system resetting
		BLINK 2 = Not connect to router
		BLINK 3 = WiFi server problem
		BLINK = RS485 connected
 Run		On = Inverter is feeding power
		OFF = Inverter is not feeding power at the moment
 Fault		On = Fault occurred
		OFF = No fault

### 5.2 User Interface And System Configuration

#### 5.2.1 Operation Method

There are 2 modes of button operation: Short press the button and long press the button.

In all levels of menu, if no action is taken, the backlight of the LCD will switch off, the LCD will automatically revert to the first item of the first level menu, and any modifications made to the data will be stored into internal memory.

#### 5.2.2 Set Safety Country

If LCD displays "Configure Safety", then long press the button to enter the second level menu. Short press to browse the safety country available. Choose suitable safety country according to the location of installation.

#### 5.2.3 LCD

A schematic of the display screen is shown as below:

Normal  
Pac=XXXX.XW

Display area is divided as follows:

Line ①  
Line ②

### 5.2.4 Display Area

Line 1 --- Working status information

Line 2---Diaplays of the real-time power generated by the inverter.

- This area displays the status information. "Waiting" indicates the inverter is standing by for power generation; "Checking \*\*S" (checking time is based on safety, and varies from country to country) indicates is self-checking, counting down and preparing for power generation. "Normal" indicates the inverter is generating power. If any condition of the system is abnormal, the screen will display an error message.
- Through button operation, the screen can display different information such as operation parameters and power generation status is in this area. There are two levels of menus, and the flow chart of first level menu is shown below:

### 5.2.5 Use Of The LCD

The display allows accessing the configuration of the basic parameters. All the language, time and country settings can be configured by buttons. The menu, shown in the LCD displays area has two levels of menu. Short or long press the button will take you between menus and through each menu. Items in the first level menu that have no second level are locked. For these items, when the button is pressed for two seconds, the LCD will display the word "Lock" followed by data relating to the first level menu item. The locked menu can only be unlocked under system mode switching, fault occurrence or button operation.

### 5.2.6 Menu Introduction

- When the PV panel is feeding power to the inverter, the LCD displays the first-level menu.
- The initial display is the first item to the first level menu, and the interface displays the current status of the system. It shows "Waiting" in the initial state; its display "Normal" during power generation mode; if there is something wrong with the system, an error message is displayed. Please refer to "5.3 Error message".

View PV voltage, PV current, grid voltage, current and frequency:

- Short press the button to enter the "E-Today" menu which displays the total power generation for today.
- Short press the button to enter the "E-Today" menu which displays the total power generation until today.
- Short press the button to enter the "Vpv" menu which displays the PV voltage in "V".

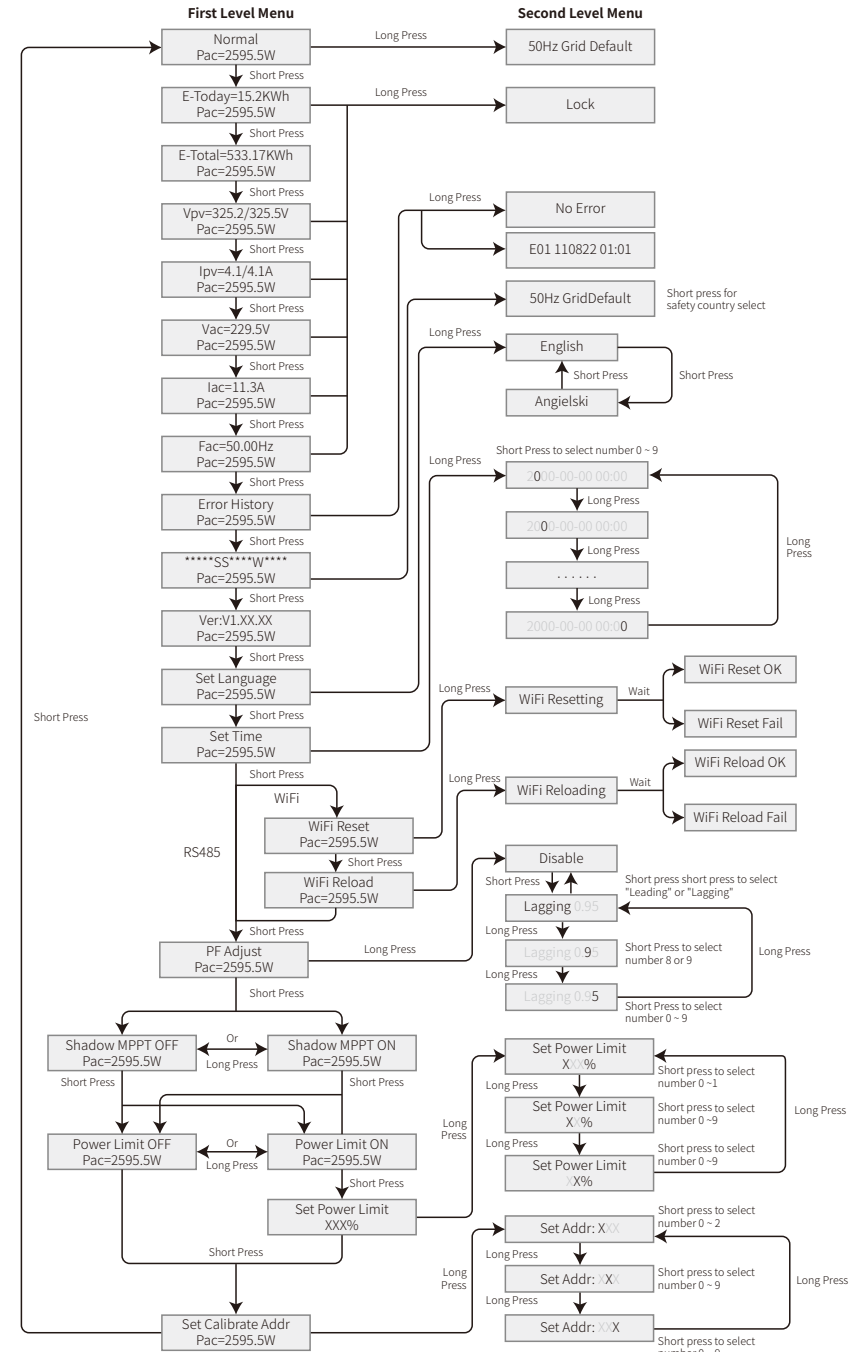

- Short press the button to enter the "Ipc" menu which displays the PV current in "A".
- Short Press the button to enter the "Vac" menu which displays the grid voltage in "V".
- Short Press the button to once more to enter the "Iac" menu which display the grid current in "A".
- Short Press the button to once more to enter the "Frequency" menu which displays the grid frequency in "Hz".

- View error code

Short press the button once more to enter the "Error Code history" menu.

Long press the button to enter the second level menu of error detection. The newest three inverter records will be shown by short pressing the button in this second level menu. The records include error codes (EXX) and error times (110316 15:30).

- View model name and reconfigure safety country:

From the error code history item in the first level menu, short press the button to see model name. If you want to change the safety country, please long press the button, then LCD will enter the second level menu. In the second level menu, short pressing the button can change the safety country.

After choosing the suitable safety country, the inverter will store the chosen safety country if there is no input for 20 seconds. If there is no exact proper country code, please choose "50Hz Grid Default" or "60Hz Grid Default" accordingly.

- View software version

From the model name item in the first level menu, short press the button to see the software version. The current software version can be shown in this menu.

### 5.2.7 Basic Setting

- Set language

Short press the button to enter the "Set Language" menu. Long press the button to enter the second level menu. Short press the button to browse the languages available.

- Set time

From the first level "Set Language" menu, short press the button to enter the "Set Time" menu.

Long press the button to enter the second level menu. The initial display is "2000-00-00 00:00", in which the first four numbers represent the year (e.g. 2000~2099); the fifth and sixth numbers represent the month (e.g. 01~12); the seventh and the eighth numbers represent the date (e.g. 01~31). The remaining numbers represent the time.

Short press the button to increase the number in current location, and press to move the cursor to next position.

- Set protocol:

The function is only used for service personnel, setting a wrong protocol could lead to communication failure. From the first level "Set Time" menu, short press the button to enter

"Set Protocol Display" menu. Long press the button to enter sub menu. The circulatory sub menu including two protocols can be found. The protocol can be chosen by short pressing the button.

- MPPT function for shadow:

The default setting for shadow optimizer is disabled.

Please enable shadow optimizer when there is shadow on PV panel. The function could help the system generate more power under shadow condition. Please do not enable the function when there's no shadows being casted onto the panel. Otherwise it could lead to lesser generated power. Press the button until it enters the shadow optimize menu. When LCD displays "Shadow MPPT OFF", it means the MPPT function for shadow is switched off. Long press the button to enable the function. If LCD displays "Shadow MPPT ON" it means the shadow optimizer is on. Long press the button to disable the function.

- 70% rated power limit

The function is only available for inverters in Germany. It can only be used by network operators. Otherwise it will cause a loss of power generated from the PV plant.

Press the button till LCD displays the 70% rated power menu. If LCD displays 70% rated enable it means the function to limit the inverter working under 70% of rated output is switched off. Long press the button will switch this function on. If LCD displays recover rated power it means the inverter is working under 70% of rated output power. Long press the button to recover inverter to 100% of its rated output power.

### 5.2.8 Power Limiting Function Setting

- Enter Password:

Please enter the password (valid for 10 minutes) before changing the power limiting state (the default is OFF) and the power limiting setting (the default is 2% rated power): Long press the button to enter password input menu. The initial display "1111" is the default password. Short press the button to increase the number in current location and long press to move to the cursor to next position. The operations are shown as below.

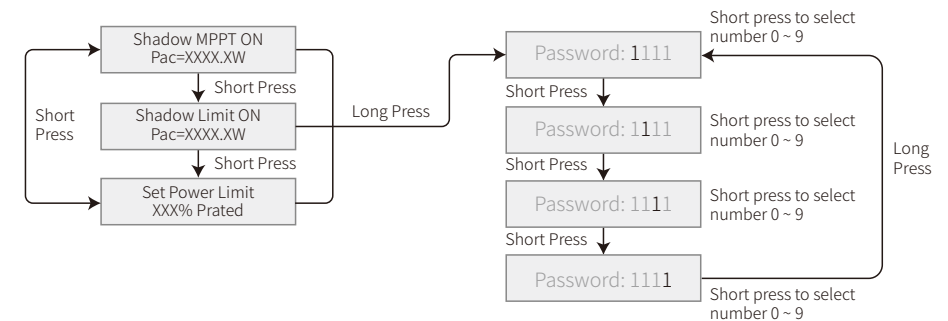

• **Modify Password:**

Long press the button to enter password change menu. Short press to increase the number in current location, long press to move the cursor to next position. If the old password is right, the new password will be stored after 20 seconds without any input.

Note: You can only enter the new password if the login is within the effective time period (10 minutes).

The operation are shown as below.

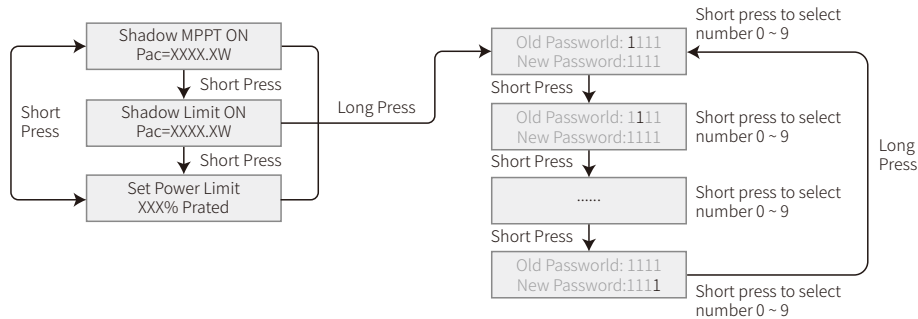

• **Power limiting function setting**

If the power limiting function is ON, the maximum output power of the inverter will be limited at the power limit setting value while the inverter is without power limiting device (such as a CT/Meter) or when the power limiting device is out of order.

**5.2.9 Auto-Test**

The default setting of this function is disabled which can only be available in Italy safety. Short press the button until LCD displays "Auto Test", and long press the button to start this function.

if auto test is finished, short press the button until LCD displays "Auto Test Result", and long press the button to check the result.

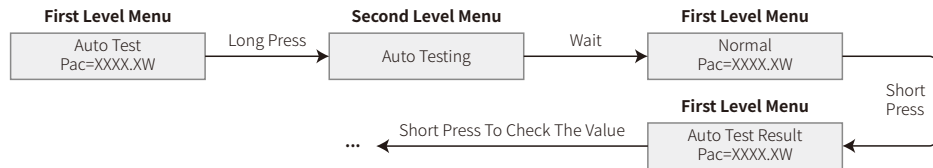

Auto test types will be chosen by "Remote" and "Local" before starting the test. "Remote" default setting is 1, unable to be modified. "Local" default setting is 0, which can be set to 0 or 1 by calibrating the software. If set "Local" to 1, testing order will be 59.S1, 59.S2, 27.S1, 81>S1, 81<S1. Otherwise, testing order will be 59.S1, 59.S2, 27.S1, 81>S2, 81<S2.

Connect AC, auto tests will begin after the inverter relays close successfully: output power is zero and LCD will show the information about testing.

If sub test finishes and LCD displays "Test \*\*\*\*\* OK", inverter relay breaks off and reconnect to grid automatically according to CEI 0-21 requirement. Then the next test starts.

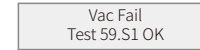

If sub test fails, inverter relay breaks off and enter wait mode. To retry, the inverter needs to be totally powered off and be restarted.

**5.2.10 Operation Of Display When Commissioning**

When the input voltage reaches the inverter's turn-on voltage, the LCD starts to work, the yellow lights is turned on and the LCD displays "Waiting". More information will be displayed within a few seconds. If the inverter is connected to the grid, "Checking 30" will be displayed and a countdown of 30 seconds will commence. When the countdown reaches "00S" you will hear the relay trigger 4 times. The LCD will then display "Normal". The instant power output will be shown at the left bottom of the LCD.

**5.3 Error Message**

An error message will be displayed on the LCD is a fault occurs.

Error code	Error message	Description
03	Fac Fail	Grid frequency out of permissible range
14	Isolation Fail	Ground insulation impedance is too low
15	Vac Failure	Grid voltage out of permissible range
17	PV Over Voltage	Overvoltage at DC input
19	Over Temperature	Over Temperature on the case
23	Utility Loss	Utility is unavailable

**5.4 Wi-Fi Reset & Wi-Fi Reload**

These functions are only available for Wi-Fi model inverters.

Wi-Fi reload function is used to change the Wi-Fi configuration to default value. Please configure the Wi-Fi again after using the function.

Short press the button until the LCD displays "Wi-Fi Reset", then long press the button until the LCD displays "Wi-Fi Resetting...". Stop pressing and wait for the screen to display "Wi-Fi Reset OK" or "Wi-Fi Reset Failed".

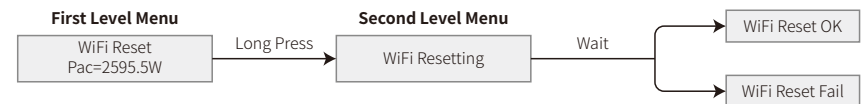

Short press the button until the LCD displays "Wi-Fi Reload", then long press the button until the LCD displays "Wi-Fi Reloading...". Stop pressing and wait for the screen to display "Wi-Fi Reload OK" or "Wi-Fi Reload Failed".

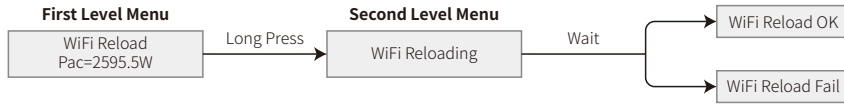

## 5.5 Precaution For Initial Startup

1. Make sure the AC circuit is connected and AC breaker is turned off.
2. Make sure the DC cable between inverter and PV string is connected, and the PV voltage is normal.
3. Turn on the DC switch, and set safety country according to the local regulation.
4. Turn on the AC breaker. Check the inverter work normal.

## 5.6 Special Adjustable Setpoints

The inverter has a field in which the user can set functions, such as trip points, trip times, reconnect times, active and inactive QU curves and PU curves. It is adjustable through special software. If needed, please contact after-sales. To obtain software manuals, you can download them from the official website or contact after-sales.

### 5.6.1 PF Power Curve Mode

PF power curve mode can be modified by Calibrate communication method, according to the set range to set the corresponding value.

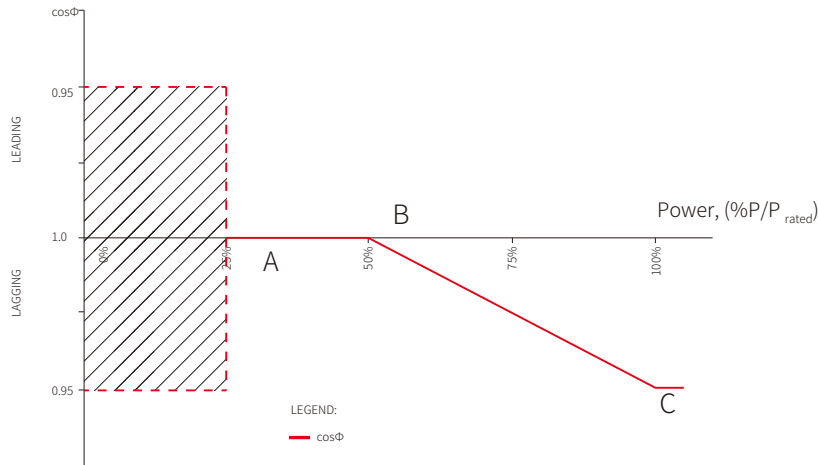

PF Power Curve Mode			
Function	Default value (Australia)	Default value (New Zealand)	Setting range
PF curve mode enable or disable	0	0	"0" or "1"
B %P/P <sub>rated</sub>	50 (50%)	50 (50%)	30%~80%
C Power factor	0.9	0.9	0.8~1

### 5.6.2 PU Curve Mode

The PU curve mode can be modified by Calibrate communication method, according to the set range to set the corresponding value.

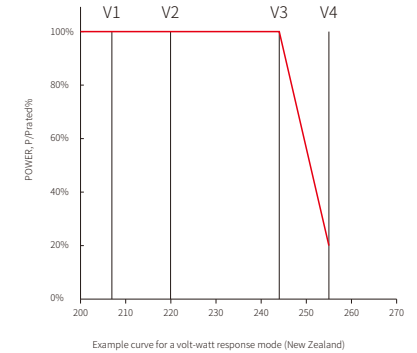
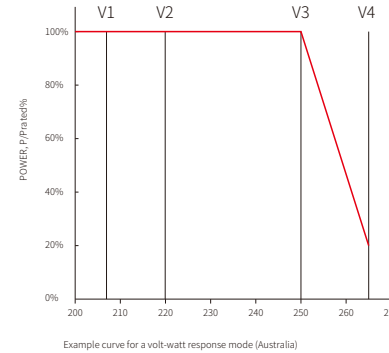

PU curve Mode			
Function	Default value (Australia)	Default value (New Zealand)	Setting range
PU curve mode enable or disable	1	1	"0" or "1"
V1 voltage ratio	207V	207V	Not applicable
P1 power ratio	100 (100%*P <sub>n</sub> )	100 (100%*P <sub>n</sub> )	0~120
V2 voltage ratio	220V	220V	216V~230V
P2 power ratio	100 (100%*P <sub>n</sub> )	100 (100%*P <sub>n</sub> )	0~120
V3 voltage ratio	250V	244V	235V~255V
P3 power ratio	100 (100%*P <sub>n</sub> )	100 (100%*P <sub>n</sub> )	0~120
V4 voltage ratio	265V	255V	244V~265V
P4 power ratio	20 (20%*P <sub>n</sub> )	20 (20%*P <sub>n</sub> )	0~120

### 5.6.3 QU Curve Mode

QU curve mode can be modified by Calibrate communication, according to the set range to set the corresponding value.

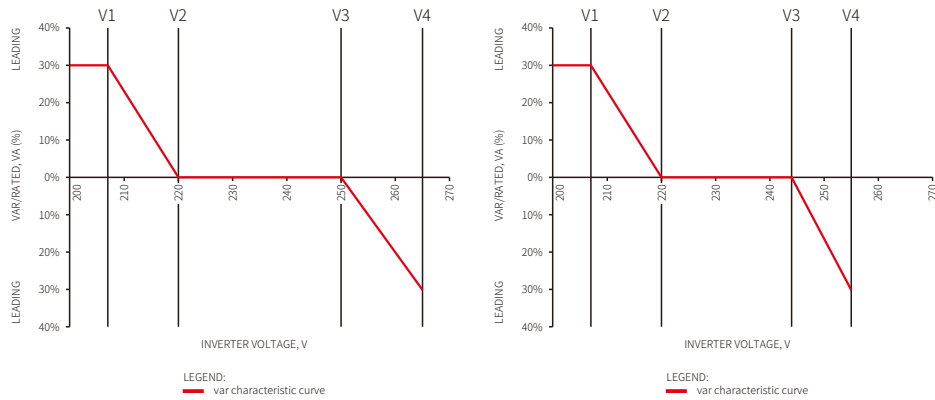

QU curve Mode			
Function	Default value (Australia)	Default value (New Zealand)	Setting range
QU curve mode enable or disable	0	0	"0" or "1"
V1 voltage ratio	207V	207V	Not applicable
Q1 reactive power ratio	30 (30%*Pn)	30 (30%*Pn)	0-60
V2 voltage ratio	220V	220V	216V-230V
Q2 reactive power ratio	0 (0%*Pn)	0 (0%*Pn)	0
V3 voltage ratio	250V	244V	235V-255V
Q3 reactive power ratio	0 (0%*Pn)	0 (0%*Pn)	0
V4 voltage ratio	265V	255V	244V-265V
Q4 reactive power ratio	30 (-30%*Pn)	30 (-30%*Pn)	0-60

### 5.6.4 Power Recovery Rate

The power recovery rate can be modified by Calibrate communication, according to the set range to set the corresponding value.

Function	The default value (Australia & New Zealand)	Setting range
Power recovery rate Settings	16 (16%Pn/min)	5-100

If you need to change the above Settings, please contact our after-sales service.

## 6 Troubleshooting

If the Inverter is not able to work properly, please refer to the following instructions before contacting your local service. If any problems arise, the red (FAULT) LED indicator on the front panel will light up and the LCD screen will display relevant information. Please refer to the following table for a list of error message and associated solutions.

Type of fault		Troubleshooting
System Failure	Isolation Failure	<ol style="list-style-type: none"> <li>1. Disconnect DC switch, take off DC connector, check the impedance between PV (+) &amp; PV(-) to earth.</li> <li>2. If impedance is less than 100 kΩ, please check the insulation of PV string wiring to earth.</li> <li>3. If impedance is large than 100 kΩ, please contact local service office.</li> <li>4. Take off AC connector, measure the impedance between neutral</li> </ol>
	Ground I Failure	<ol style="list-style-type: none"> <li>1. The ground current is too high.</li> <li>2. Unplug the inputs from the PV generator and check the peripheral AC system.</li> <li>3. When the problem is cleared, reconnect the PV panel and check the Inverter status.</li> <li>4. Contact local service office for help if the problem still persist.</li> </ol>
	Vac Failure	<ol style="list-style-type: none"> <li>1. The PV Inverter will automatically restart within 5 minutes if the grid returns to normal.</li> <li>2. Make sure grid voltage conforms with the specification.</li> <li>3. Make sure neutral (N) wire and PE wire are connected well.</li> <li>4. Contact local service office for help if the problem still persist.</li> </ol>
	Fac Failure	<ol style="list-style-type: none"> <li>1. Grid is not connected.</li> <li>2. Check grid connection cables.</li> <li>3. Check availability of grid.</li> </ol>
	Utility Loss	<ol style="list-style-type: none"> <li>1. Not connect to the grid.</li> <li>2. Check if the power grid is connected to cable.</li> <li>3. Check the availability of power grid.</li> </ol>
	PV Over Voltage	<ol style="list-style-type: none"> <li>1. Check if the PV open circuit voltage is higher or too close to the maximum input voltage or not.</li> <li>2. If the problem still persist when PV voltage is less than the maximum input voltage, contact local service office for help.</li> </ol>
	Over Temperature	<ol style="list-style-type: none"> <li>1. The internal temperature is higher than normal value specified.</li> <li>2. Reduce ambient temperature.</li> <li>3. Move the inverter to a cool place.</li> <li>4. If the problem still exists, contact local service office for help.</li> </ol>



Type of fault		Troubleshooting
Inverter Failure	Relay-Check Failure	<ol style="list-style-type: none"> <li>1. Turn off DC switch of the inverter.</li> <li>2. Wait till the inverter's LCD light is off.</li> <li>3. Turn on DC switch and make sure it is connected.</li> <li>4. If the problem still exists, contact local service office for help.</li> </ol>
	DCI Injection High	
	EEPROM R/W Failure	
	SCI Failure	
	SPI Failure	
	DC BUS High	
	BUS Unbalance	
	GFCI Failure	
	Ifan Fault	
	Efan Fault	
	Afan Fault	
	No display	<ol style="list-style-type: none"> <li>1. Turn off DC switch, take off DC connector, measure the voltage of PV array.</li> <li>2. Plug in DC connector, and turn on DC switch.</li> <li>3. If PV array voltage is lower than 250V , please check configuration of inverter module.</li> <li>4. If voltage is higher than 250V , please contact local office.</li> </ol>
Others	Wi-Fi module fail to connect to network	<ol style="list-style-type: none"> <li>1. If the Wi-Fi module fail to connect to network after choosing the right router hotspot and entering the right passwords, it's possible that there are special characters not supported by module in the hotspot passwords. Please modify the password to consist of only Arabic numerals or uppercase / lowercase letters.</li> <li>2. If the problem still exists, contact local service office for help.</li> </ol>

Note:

When sunlight is insufficient, the PV inverter may continuously start up and shut down automatically due to insufficient power generation from the PV panels, which would not lead to inverter damage.

## 7 Maintenance

Regular maintenance of the inverter ensures its service life and optimal efficiency.

Note: Disconnect the AC circuit breaker, then turn off the DC switch. Wait for 5 minutes to release residual voltage before maintenance.

### 7.1 DC Switch Check

The DC switch does not need extra maintenance if it's in use. Just check whether it can work properly.

Keep the inverter shutdown before checking.

Turn the DC switch on and off 10 times continually once a year.

Turn the switch regularly can clean up the device and extend its service life.

Boot order:

1. Set the circuit breaker on the AC side to ON.

2. Set the DC switch to ON.

Caution: Skip this step if no DC switch.

3. Set the circuit breaker on the DC side to ON.

Shutdown order:

1. Set the circuit breaker on the AC side to OFF.

2. Set the DC switch to OFF.

Caution: Skip this step if no DC switch.

3. Set the circuit breaker on the DC side to OFF.

### 7.2 Electrical connection check

Maintenance period: once a half year.

1. Check whether the cables are securely connected.

2. Check whether the PE cables are reliably grounded

3. Check whether the waterproof covers for ports are locked.

## 8 Technical Parameters

Technical Data	GW700-XS	GW1000-XS	GW1500-XS	GW2000-XS
<b>Input</b>				
Max.Input Power (W)	910	1300	1950	2600
Max.Input Voltage (V)	500	500	500	500
MPPT Operating Voltage Range (V)	40~450	40~450	50~450	50~450
MPPT Voltage Range at Nominal	80~450	85~450	125~450	165~450
Start-up Voltage (V)	40	40	50	50
Nominal Input Voltage (V)	360	360	360	360
Max. Input Current per MPPT (A)	12.5	12.5	12.5	12.5
Max. Short Circuit Current per MPPT	15.6	15.6	15.6	15.6
Max.Backfeed Current to The Array	0	0	0	0
Number of MPPT	1	1	1	1
Number of Strings per MPPT	1	1	1	1
<b>Output</b>				
Nominal Output Power (W)	700	1000	1500	2000
Max. AC Active Power (W)	800	1100	1650	2200
Max. AC Apparent Power (VA)	800*	1100*	1650*	2200*
Nominal Output Voltage (V)	230	230	230	230
Nominal AC Grid Frequency (Hz)	50/60	50/60	50/60	50/60
Max. Output Current (A)	3.5	4.8	7.2	9.6
Max. Output Fault Current(peak and duration) (A/ms)	25/5	25/5	25/5	25/5
Inrush Current(peak and duration) (A/us)	50/2	50/2	50/2	50/2
Nominal Output Current (A)	3	4.3	6.5	8.7
Output Power Factor	~1 (Adjustable from 0.8 leading to 0.8 lagging)			
Max. Total Harmonic Distortion	<3%			
<b>Efficiency</b>				
Max. Efficiency	0.972	0.972	0.973	0.975
European Efficiency	0.96	0.964	0.966	0.97
<b>Protection</b>				
DC Insulation Resistance Detection	Integrated			
Residual Current Monitoring Unit	Integrated			
Anti-islanding Protection	Integrated			
AC Overcurrent Protection	Integrated			
AC Short Circuit Protection	Integrated			
AC Overvoltage Protection	Integrated			
DC Switch	Integrated			
DC Surge Arrester	Type III			
AC Surge Arrester	Type III			
<b>General Data</b>				
Operating Temperature Range (°C)	-25~60			
Relative Humidity	0~100%			
Max. Operating Altitude (m)	≤4000			
Cooling Method	Natural Convection			

Technical Data	GW700-XS	GW1000-XS	GW1500-XS	GW2000-XS
<b>General Data</b>				
Display	LED+LCD/WiFi+APP/Bluetooth+APP			
Communication	WiFi / LAN / RS485			
Weight (Kg)	5.8			
Dimension (W×H×Dmm)	295×230×113			
Noise Emission (dB)	25			
Topology	Transformerless			
Night Power Consumption (W)	<1			
Ingress Protection Rating	IP65			
DC Connector	MC4 (2.5~4mm <sup>2</sup> )			
AC Connector	plug and play connector			
Environmental Category	4K4H			
Pollution Degree	III			
Overvoltage Category	DC II / AC III			
Protective class	Class I			
The Decisive Voltage Class (DVC)	C			

Technical Data	GW2500-XS	GW3000-XS	GW2500N-XS	GW3000N-XS
<b>Input</b>				
Max.Input Power (W)	3250	3900	3250	3900
Max.Input Voltage (V)	500	500	600	600
MPPT Operating Voltage Range (V)	50~450	50~450	50~550	50~550
MPPT Voltage Range at Nominal Power (V)	205~450	245~450	200~450	240~450
Start-up Voltage (V)	50	50	50	50
Nominal Input Voltage (V)	360	360	360	360
Max. Input Current per MPPT (A)	12.5	12.5	13	13
Max. Short Circuit Current per MPPT	15.6	15.6	16.3	16.3
Max.Backfeed Current to The Array	0	0	0	0
Number of MPPT	1	1	1	1
Number of Strings per MPPT	1	1	1	1
<b>Output</b>				
Nominal Output Power (W)	2500	3000	2500	3000
Max. AC Active Power (W)	2750	3300	2750	3300
Max. AC Apparent Power (VA)	2750*	3300*	2750*	3300*
Nominal Output Voltage (V)	230	230	220/230	220/230
Nominal AC Grid Frequency (Hz)	50/60	50/60	50/60	50/60
Max. Output Current (A)	12	14.3	12	14.3
Max. Output Fault Current(peak and duration) (A/ms)	30/5	30/5	30/5	30/5
Inrush Current(peak and duration) (A/us)	50/2	50/2	50/2	50/2
Nominal Output Current (A)	10.9	13	11.4/10.9	13.6/13
Output Power Factor	~1 (Adjustable from 0.8 leading to 0.8 lagging)			
Max. Total Harmonic Distortion	<3%	<3%	<3%	<3%

Technical Data	GW2500-XS	GW3000-XS	GW2500N-XS	GW3000N-XS
<b>Efficiency</b>				
Max. Efficiency	0.976	0.976	0.976	0.976
European Efficiency	0.972	0.972	0.972	0.972
<b>Protection</b>				
DC Insulation Resistance Detection	Integrated			
Residual Current Monitoring Unit	Integrated			
Anti-islanding Protection	Integrated			
AC Overcurrent Protection	Integrated			
AC Short Circuit Protection	Integrated			
AC Overvoltage Protection	Integrated			
DC Switch	Integrated			
DC Surge Arrester	Type III		Type III(Type II Optional)	
AC Surge Arrester	Type III	Type III	type III	type III
DC Arc Fault Circuit Interrupter	NA	NA	Optional	Optional
<b>General Data</b>				
Operating Temperature Range (°C)	-25~60			
Relative Humidity	0~100%			
Max. Operating Altitude (m)	≤4000			
Cooling Method	Natural Convection			
Display	LED+LCD/WiFi+APP/Bluetooth+APP			
Communication	WiFi / LAN / RS485		RS485 / WiFi	
Weight (Kg)	5.8			
Dimension (W×H×Dmm)	295×230×113			
Noise Emission (dB)	42			
Topology	Transformerless			
Night Power Consumption (W)	<1			
Ingress Protection Rating	IP65			
DC Connector	MC4 ( 2.5~4mm <sup>2</sup> )			
AC Connector	plug and play connector			
Environmental Category	4K4H			
Pollution Degree	III			
Overvoltage Category	DC II / AC III			
Protective class	Class I			
The Decisive Voltage Class (DVC)	C			

Technical Data	GW3KB-XS	GW3300-XS
<b>Input</b>		
Max.Input Power (W)	3900	3900
Max.Input Voltage (V)	600	500
MPPT Operating Voltage Range (V)	50~550	50~450
MPPT Voltage Range at Nominal Power (V)	240~450	275~450
Start-up Voltage (V)	50	50
Nominal Input Voltage (V)	360	360
Max. Input Current per MPPT (A)	13	12.5
Max. Short Circuit Current per MPPT (A)	16.3	15.6
Max.Backfeed Current to The Array (A)	0	0
Number of MPPT	1	1
Number of Strings per MPPT	1	1
<b>Output</b>		
Nominal Output Power (W)	3000	3300
Max. AC Active Power (W)	3300	3300
Max. AC Apparent Power (VA)	3300*	3300
Nominal Output Voltage (V)	220/230	230
Nominal AC Grid Frequency (Hz)	50/60	50/60
Max. Output Current (A)	14.3	14.3
Max. Output Fault Current(peak and duration)	30/5	30/5
Inrush Current(peak and duration) (A/us)	50/2	50/2
Nominal Output Current (A)	13.6/13	14.3
Output Power Factor	~1 (Adjustable from 0.8 leading to 0.8 lagging)	
Max. Total Harmonic Distortion	<3%	
<b>Efficiency</b>		
Max. Efficiency	0.976	
European Efficiency	0.972	
<b>Protection</b>		
DC Insulation Resistance Detection	Integrated	
Residual Current Monitoring Unit	Integrated	
Anti-islanding Protection	Integrated	
AC Overcurrent Protection	Integrated	
AC Short Circuit Protection	Integrated	
AC Overvoltage Protection	Integrated	
DC Switch	Integrated	
DC Surge Arrester	Type III	
AC Surge Arrester	Type III	
DC Arc Fault Circuit Interrupter	Optional	
<b>General Data</b>		
Operating Temperature Range (°C)	-25~60	-25~60
Relative Humidity	0~100%	0~100%
Max. Operating Altitude (m)	≤4000	≤3000
Cooling Method	Natural Convection	

Technical Data	GW3KB-XS	GW3300-XS
<b>General Data</b>		
Display	LED+LCD/WiFi+APP/Bluetooth+APP	
Communication	RS485 / WiFi	WiFi / LAN / RS485
Weight (Kg)	5.8	
Dimension (W×H×Dmm)	295×230×113	
Noise Emission (dB)	42	
Topology	Transformerless	
Night Power Consumption (W)	<1	
Ingress Protection Rating	IP65	
DC Connector	MC4 (2.5~4mm <sup>2</sup> )	
AC Connector	plug and play connector	
Environmental Category	4K4H	
Pollution Degree	III	
Overvoltage Category	DC II / AC III	
Protective class	Class I	
The Decisive Voltage Class (DVC)	C	

\*For Belgium Max. Output Apparent Power(VA): GW700-XS is 700;GW1000-XS is 1000; GW1500-XS is 1500; GW2000-XS is 2000; GW2500-XS or GW2500N-XS is 2500; GW3000-XS or GW3000N-XS is 3000.

Note:

### Overvoltage Category Definition

Category I: applies to equipment connected to a circuit where measures have been taken to reduce transient overvoltage to a low level.

Category II: applies to equipment not permanently connected to the installation. For example, appliances, portable tools and other plug-connected equipment;

Category III: applies to fixed downstream equipment, including the main distribution board. For example, switchgear and other equipment in an industrial installation;

Category IV: applies to equipment permanently connected at the origin of an installation (upstream of the main distribution board). For example, electricity meters, primary overcurrent protection equipment and other equipment connected directly to outdoor open lines.

### Moisture Location Category Definition

Moisture parameters	Level		
	3K3	4K2	4K4H
Temperature Range	0~+40°C	-33~+40°C	-20~+55°C
Humidity Range	5%~85%	15%~100%	4%~100%

### Environment Category Definition

Outdoor : the ambient air temperature is -20~50°C. Relative humidity range is from 4% to 100%, applied to PD3.

Indoor unconditioned: the ambient air temperature is -20~50 °C. Relative humidity range is from 5% to 95%, applied to PD3.

Indoor conditioned: the ambient air temperature is 0~40 °C. Relative humidity range is from 5% to 85%, applied to PD2.

### Pollution Degree Definition

Pollution degree 1: No pollution or only dry, non-conductive pollution occurs. The pollution has no influence.

Pollution degree 2: Normally only non-conductive pollution occurs. However, a temporary conductivity occasionally caused by condensation must be expected.

Pollution degree 3: Conductive pollution occurs. Or dry, non-conductive pollution becomes conductive due to condensation, which is expected.

Pollution degree 4: Persistent conductive pollution occurs. For example, the pollution cause by conductive dust, rain and snow.